

Powerbor®

POWERBOR - PB1000E DRILL OWNERS MANUAL



WARNING !

When using electric power tools basic safety precautions should always be used to reduce the risk of fire, electric shock and personal injury.

Read all of these instructions before attempting to operate this product and save these instructions



Machine shown
PB1000E - without the
safety guard for clarity.

G & J Hall Tools Inc. 830 Hanley Industrial Court, Brentwood, MO 63144 USA
Phone: (314) 968-5040 Fax: (314) 968-5543 e-mail: sales@gjhalltools.com

PB1000E US - Revised 030511

PAGE INDEX**Page No.**

Machine Specification	3
Explanation of symbols used	4
Intended use of power tool	5
Prohibited use of power tool	5
Safety precautions	
1 - Precautions and use of PPE.	6
2 - Special safety precautions - Magnetic Drills.	7
3 - Electrical safety	8
4 - Dust Extraction	8
5 - General safety instructions.	9-10
Installation instructions	
1 - Unpacking and Assembly	11
2 - Setting-up or fixing tool in a stable position.	11
3 - Connection to power supply.	11
4 - Illustrated description of functions	12
5 - Limitations on ambient conditions	13
6 - Standard Accessories	13
7 - Disassembly and transportation	13
Operating instructions	
1 - Setting and testing.	14
2 - Tool changing.	
Mounting of cutters into the arbor.	14
Fitting the MT3 arbor.	15
Removing the MT3 arbor.	15
Using Twist Drills.	15
3 - Guards	16
4 - Clamping of work. (Magnet Control)	16
5 - Limits on size of work piece and type of material.	
Cutting Speeds/Materials—HSS cutters	17
Workpiece Material and size Limitations	17
6 - General instructions for use.	
Drill unit spindle control	18
Drill unit speed control	18
Reversing of the handles	19
Normal operator position	19
Using the drill with annular cutters	20
7 - Lifting handles/transportation.	5
Maintenance and servicing	
1 - Regular cleaning, maintenance and lubrication.	21
2 - Servicing by manufacturer.	22
3 - Special Tools	13
4 - Blockages of chips or work piece fragments.	20

MACHINE SPECIFICATION

PB1000E

Machine Height	17 ¹⁵ / ₁₆ " (slide in down position)	
Machine Width	6 ⁵ / ₁₆ " (without handles)	
Machine Depth	14 ³ / ₁₆ "	
Stroke	10 ¹ / ₄ "	
Machine Weight	55lb (tool and detachable parts)	
Rated Motor Power	1700W	
Voltage	110V / 230V AC	
Rated Current	15.5A / 7.9A	
IP Rating	IP20	
Spindle Speed - load	110 / 175 / 245 / 385 rpm	
Spindle Speed - no	200 / 320 / 445 / 700 rpm	
No. of speeds	4 Gears	
FWD/REV	No	
Power Cord Length	8' 2"	
Insulation Class	CLASS I	
Annular Cutter Capacity	Ø4" (needs optional 1 ¹ / ₄ " arbor above Ø2 ¹ / ₂ ")	
Standard Cutting Depth	2"	
Twist Drill Capacity	Ø1 ¹ / ₄ " with MT3 shank	
Tapping Capacity	N/A	
Countersink	Yes	
Chuck Type	³ / ₄ " Weldon Shank Arbor or MT3	
Spindle Fitting	MT3	
Magnet Dimensions	8 ⁵ / ₈ " x 4 ⁵ / ₁₆ "	
Magnet Power	95W	
Magnetic Adhesion	4400lb (measured on 1" thick plate)	
Minimum Plate Thickness	³ / ₈ " (minimum recommended)	
Sound Pressure Level	86 dBA	Uncertainty 3 dBA
Sound Power Level	99 dBA	Uncertainty 3 dBA
SPL at Operators Head	89 dBA (1.55m high x 1m distance)	Uncertainty 3 dBA
Hand-arm Vibration	Less than 2.5 m/s ²	Uncertainty 1.5m/s ² .

The vibration measurement was made under standard conditions in accordance with the requirements of BS EN 60129-1:2009.

The actual vibration level during use will depend on the workpiece stability/rigidity and the condition of the cutter used. These factors may increase the vibration experienced by the operator, each individual application of the tool should be assessed for the effect of these application variable factors, before exposure.









PB1000E SB

The PB1000E SB is the same specification as above but with the additional feature of a moveable base to allow positioning of the drill whilst the magnet is energised.

The swivel base option adds approx 3/8" to the overall height.

The swivel is 60° left or right and the whole drill unit can move 3/4" back and forth.

EXPLANATION OF SYMBOLS USED

Symbol	Meaning
	Eye protection should be worn at all times when using this tool.
	Hard Hat—Head protection should be worn at all times whilst using this tool, to protect from overhead hazards
	Ear protection / Ear defenders should be worn at all times whilst using this tool, this tool exceed 85dB(A)
	Electrical enclosure - risk of electric shock.
	Read and understand the instruction manual - before operating this tool.
	Caution ! / Attention !
	Instruction Manual
	WEEE - Waste of Electrical and Electronic Equipment This tool should be disposed of as Electrical & Electronic Waste.

INTENDED OF USE OF POWER TOOL

This power tool is intended to be used for drilling holes with annular cutters, twist drills, counterbores, countersinks and step drills in an industrial environment.

The machine is meant to be held onto a magnetisable surface using its electro-magnetic base.

The power tool should be used in a weather protected environment and be used with the accessories provided or Powerbor recommended accessories only.

The power tool can be used vertically, horizontally and upside down, provided the magnetic adhesion and work environment allow.

Cutting paste should be used rather than cutting fluid when using the machine in the upside down position to prevent ingress of fluids into the electrical system.

PROHIBITED USE OF POWER TOOL

This power tool should never be used without a ground or protective earth connection.

This power tool should not be used in a potentially explosive environment.

This power tool should not be use in a wet or humid environment where water could be drawn into the power tools cooling and ventilation system.

If the power tool is used in the upside down position, cutting fluids should not be used to prevent ingress of fluids into the electrical system, cutting paste should be used instead.

This power tool should never be positioned on a workpiece between the electrode and ground of an arc type welder. Damage to the machine will result as the welder will ground through the power tools ground or earth cable.

This power tool should not be used where the voltage is abnormally lower than the rated voltage, subject to voltage tolerances. Check the power tool rating plate, check the voltage available.

Operating on a lower than rated voltage will result in the electro magnet being at reduced power and the machine may become insecure whilst drilling.

LIFTING HANDLES - TRANSPORTATION

When lifting the tool the lifting handles shown in the diagram on the right should be used.

The drill unit should be lowered to its lowest position for improved stability.

Under no circumstances should the motor cable be used for lifting the power tool.

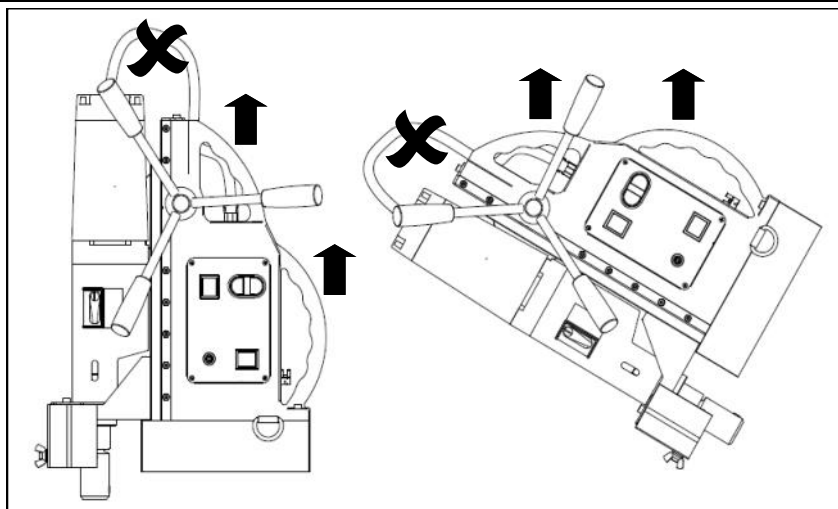

PERSONAL SAFETY AND USE OF PPE

Attention

Always watch what you are doing and use common sense at all times when operating power tools.

Do not use the power tool whilst tired, or under the influence of drugs, alcohol or medication.

A moment of inattention when using a power tool may result in personal injury.

Clothing

Always dress appropriately, do not wear loose clothing or jewellery.

Contain long hair, keep your hair, clothing and gloves away from any moving parts.

Loose clothes, jewellery or long hair can be caught in moving parts.

Accidental Start-up

Be sure all switches are in their OFF positions before plugging in the machine.

When carrying or moving tools always keep your fingers away from the switches

Plugging in a power tool with the switches in the ON position could invite accidents.

Intentional Start-up

Before starting up the power tool always remove any adjusting keys or tools.

A wrench key left in a rotating part of the power tool may result in injury.

Over Reaching

Never over reach when using a power tool. Always ensure you have a proper stable footing and balance at all times before operating the tool.

Proper footing and balance enables better control of the tool in case of unexpected situations.

Personal Protective Equipment

Always wear eye protection.

Always wear ear protection.

Always wear head protection.

Always wear non-skid safety shoes.

Where appropriate wear a dust mask and gloves depending on the working environment.

WORK IN A SAFE MANNER AT ALL TIMES

SPECIAL SAFETY PRECAUTIONS - MAGNETIC DRILLS

Safety Strap

The electro-magnet base on this power tool can release if there is a interruption in power supply or electrical malfunction.

The safety strap provided should be used at all times to prevent the power tool from falling in the event of power failure or electrical malfunction, possibly causing injury.

The safety ratchet strap should be attached to the fixing points provided and checked for security before commencing any drilling operation.

Magnetic Adhesion

The magnets strength depends on the thickness and condition of the work piece material. Always ensure that the work piece has a minimum thickness of 12mm or 1/2" to ensure there is adequate magnetic adhesion.

If the work piece is less than 1/2" then a piece of steel plate 1/2" in thickness and larger than the magnet footprint must be inserted between the magnet and work piece to supplement the magnetic adhesion.

The surface on which the magnet is placed should be clean, flat and clear from debris or rust. The base of the magnet should be inspected to ensure it is also clean flat and clear of debris.

Always check the magnet is securely adhered to the work piece before commencing any drill operations.

Do not use other appliances on the same power receptacle, any variation in voltage cause by other appliances could result in the magnet releasing. Always us the tool on its own power receptacle.

This power tool can be used on a vertical surface or upside down provided there is sufficient magnetic adhesion, extra care should be taken when drilling vertically or upside down . When using the machine vertically or upside down it is possible hot and sharp swarf or chips may fall. Always wear appropriate personal protective equipment

When Cutting

When using coolant or lubricants, ensure coolants and lubricants do not enter the drill units ventilation/cooling openings.

If the drill is used in the upside down position, use cutting paste instead of cutting fluid to prevent the possibility of fluids entering the electrical system.

When using annular cutters ensure that the slug ejected at the end of the cut will not endanger anyone in the vicinity, if working at height some form of collection device for the ejected slug may be necessary.

Care should be taken with the ejected slug, this will be both hot and sharp, gloves should be worn when handling the slug.

ELECTRICAL SAFETY

Earthing / Grounding.

This power tool requires a ground or earth connection.

The power tool must be plugged into an outlet properly installed and grounded or earthed in accordance with all local codes and regulations.

Never remove or tamper with the ground or earth prong in any way.

Do not use adaptor plugs.

If the tool should electrically malfunction or breakdown, grounding or earthing will provide a low resistance path to carry harmful electricity away from the user.

Power Cord

Never carry the power tool by its power cord or electrical hose.

Keep power cords away from heat, oil and sharp edges.

Never pull the power cord to disconnect it from the receptacle.

Always carry the power tool properly with the carrying handles provided.

Periodically inspect the power cord for damage,

If any damage is found the power tool should not be used until the damage has been repaired by a qualified electrician.

A damaged power cord will increase the risk of electric shock.

Using the Power Tool Outside

Do not expose the power tool to rain or wet conditions, water entering the power tool will increase the risk of electric shock.

When operating the power tools outside, if required, an extension cord rated for outdoor use should be used.

These extension cords are rated for outdoor use and reduce the risk of electric shock.

Electrical Enclosure

The electrical components on this power tool are housed within the main body casting, this and the side panels of the main body create an electrical enclosure.

The panels should not be removed except by a suitable trained or qualified electrician.

DUST EXTRACTION

This tool is intended for drill holes in ferrous metals, if using on materials such as cast iron where dust might be created, suitable dust extraction should be used.

This is both to protect the operator and to protect the motor inlet from ingress of harmful dust particles.

Operators should wear suitable dust masks if dust is created whilst working.

GENERAL SAFETY

- 1 - Keep work area clear
Cluttered areas and benches invite injuries.
- 2 - Consider work area environment
Do not expose tools to rain.
Do not use tools in damp or wet locations.
Keep work area well lit.
Do not use tools in the presence of flammable liquids or gases.
- 3 - Guard against electric shock
Avoid body contact with earthed or grounded surfaces
(e.g. pipes, radiators, ranges, refrigerators).
- 4 - Keep other persons away
Do not let persons, especially children, not involved in the work touch the tool or the extension cord and keep them away from the work area.
- 5 - Store idle tools
When not in use, tools should be stored in a dry locked-up place, out of reach of children.
- 6 - Do not force the tool
It will do the job better and safer at the rate for which it was intended.
- 7 - Use the right tool
Do not force small tools to do the job of a heavy duty tool.
Do not use tools for purposes not intended; for example do not use circular saws to cut tree limbs or logs.
- 8 - Dress properly
Do not wear loose clothing or jewellery, they can be caught in moving parts.
Non-skid footwear is recommended when working outdoors.
Wear protective hair covering to contain long hair.
- 9 - Use protective equipment
Use safety glasses.
Use face or dust mask if working operations create dust.
- 10 - Connect dust extraction equipment
If the tool is provided for the connection of dust extraction and collecting equipment, ensure these are connected and properly used.
- 11 - Do not abuse the cord
Never yank the cord to disconnect it from the socket. Keep the cord away from heat, oil and sharp edges.
- 12 - Secure work
Where possible use clamps or a vice to hold the work. It is safer than using your hand.
- 13 - Do not overreach
Keep proper footing and balance at all times.

GENERAL SAFETY - CONT.

- 14 - Maintain tools with care
 - Keep cutting tools sharp and clean for better and safer performance.
 - Follow instruction for lubricating and changing accessories.
 - Inspect tool cords periodically and if damaged have them repaired by an authorized service facility.
 - Inspect extension cords periodically and replace if damaged. Keep handles dry, clean and free from oil and grease
- 15 - Disconnect tools
 - When not in use, before servicing and when changing accessories such as blades, bits and cutters, disconnect tools from the power supply.
- 16 - Remove adjusting keys and wrenches
 - Form the habit of checking to see that keys and adjusting wrenches are removed from the tool before turning it on.
- 17 - Avoid unintentional starting
 - Ensure switch is in "off" position when plugging in.
- 18 - Use outdoor extension leads
 - When the tool is used outdoors, use only extension cords intended for outdoor use and so marked.
- 19 - Stay alert
 - Watch what you are doing, use common sense and do not operate the tool when you are tired.
- 20 - Check damaged parts
 - Before further use of tool, it should be carefully checked to determine that it will operate properly and perform its intended function.
 - Check for alignment of moving parts, binding of moving parts, breakage of parts, mounting and any other conditions that may affect its operation.
 - A guard or other part that is damaged should be properly repaired or replaced by an authorized service centre unless otherwise indicated in this instruction manual.
 - Have defective switches replaced by an authorized service centre.
 - Do not use the tool if the switch does not turn it on and off.
- 21 - Warning
 - The use of any accessory or attachment other than one recommended in this instruction manual may present a risk of personal injury.
- 22 - Have your tool repaired by a qualified person
 - This electric tool complies with the relevant safety rules. Repairs should only be carried out by qualified persons using original spare parts, otherwise this may result in considerable danger to the user.

UNPACKING AND ASSEMBLY

The Powerbor PB1000E and PB1000E SB come in a rugged blow moulded carrying case
Before first use:-

1. Remove the machine from the carrying case. (Note:- 55lb weight)
2. Fit the three screw in handles to the pinion shaft.
3. Fit the safety guard as shown in the instructions, see "Using the safety guard"
4. Fit the arbor, as detailed in the instructions under "Fitting the MT3 Arbor"

SETTING UP THE TOOL

Before using the tool please ensure you have read the sections on the intended and prohibited of use of the machine.

The machine should only be used for hole drilling whilst attached to the work piece by the electro-magnetic base.

This machine is intended for use at any angle, but only if the electro-magnet is in full working order and has sufficient hold on the work piece material.

The safety strap should be attached in case of power failure or machine malfunction.

The safety strap should NOT be used as an alternative to the magnet for clamping purposes.

Always ensure the strap is correctly fitted and the machine is secure BEFORE starting the motor unit

CONNECTION TO THE POWER SUPPLY

Connection to the power supply is by 8' 2" long cable and 3 pin plug.

This tool is CLASS I insulation and MUST be earthed, any power socket the tool is connected to must have an earth.

Before the power cord is connected the magnet switch should be in the OFF position.

The power cord assembly is a custom terminated one, replacement should only be carried out by a qualified electrician. Only use the replacement parts listed below.

Power cord part number:-

18X503/A

For connection information, should the power cord need to be replaced, please refer to the wiring diagram in this manual or the connection label inside the rear panel of the power tool.

ILLUSTRATED DESCRIPTION OF FUNCTIONS

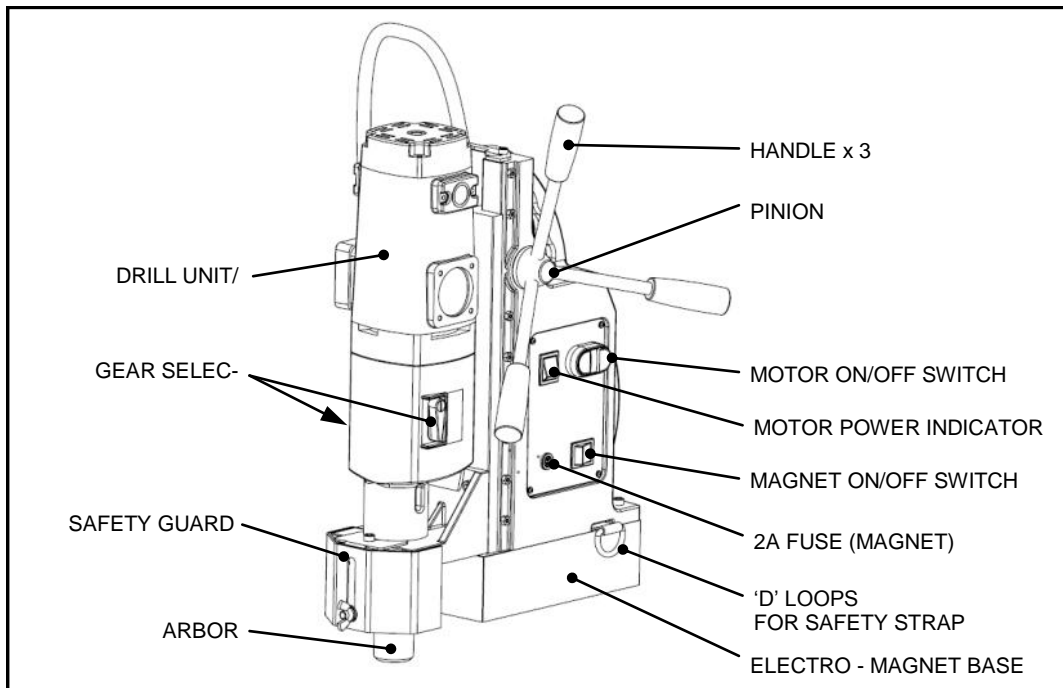
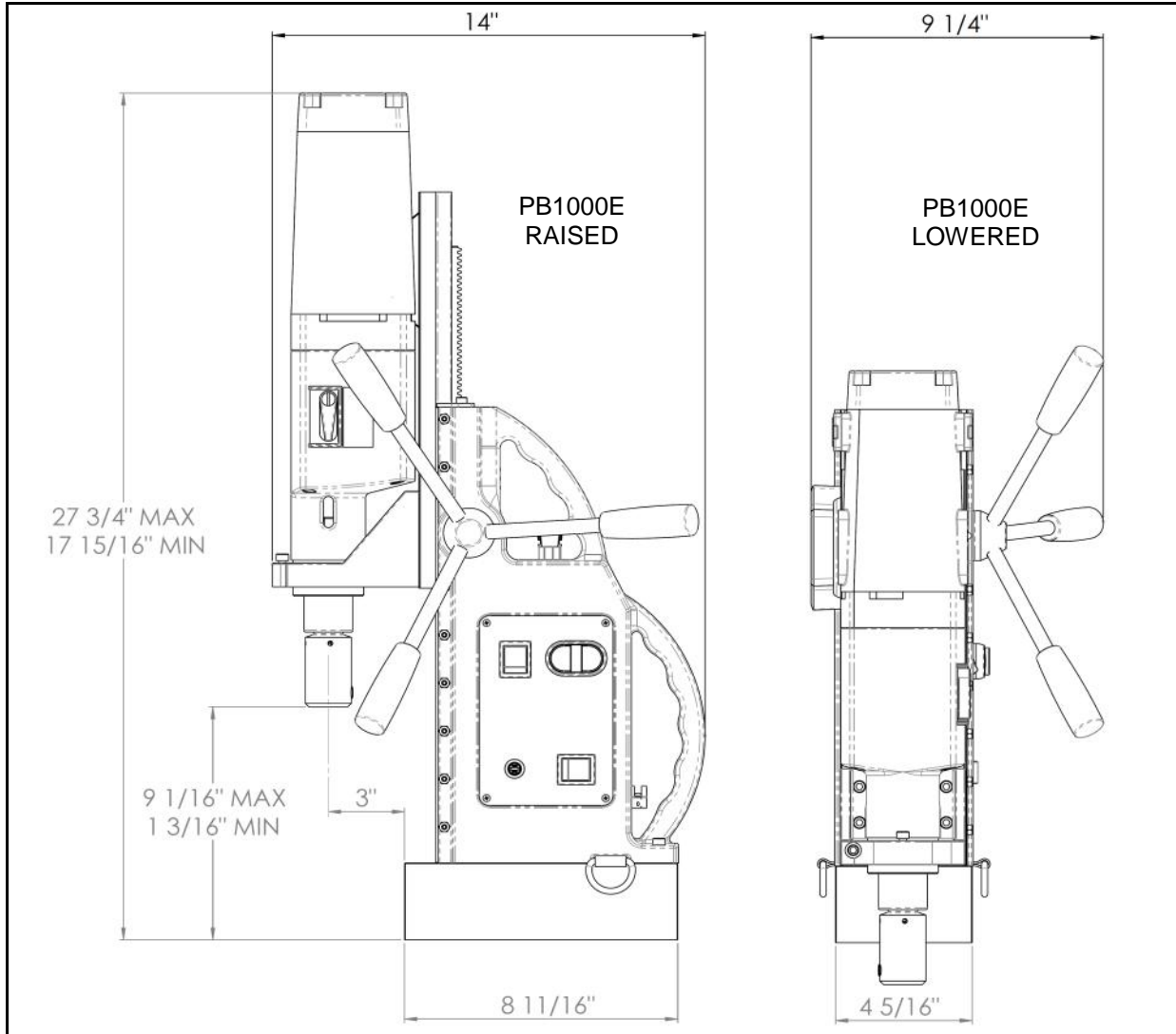

LIMITATIONS ON AMBIENT CONDITIONS

This power tool is has an ingress protection rating of IP20, it should not be used in dusty or damp environments.

The power tool should be used in a weather protected environment.

Precautions should be taken to ensure dust does not enter the ventilation system of the power tool causing clogging and overheating.

Power tools produce sparks that may ignite flammable substances such as gases, flammable liquids or dust.

Do not operate this power tool in a potentially explosive environment.

STANDARD ACCESSORIES

The PB1000E is supplied in a rugged carrying case with the following as standard :-

- MT3 to 3/4" Weldon Shank Arbor (2" cut depth)
- Safety Ratchet Strap
- Safety Guard
- 250ml Bottle of Cutting Oil
- Allen Key Set
- Drill Drift

DISASSEMBLY & TRANSPORTATION

When the machine is not in use it should be stored in the carrying case provided.

Any cutters should be removed after use.

The drill unit should be wound down into a low position.

The three pinion handles need to be removed before placing the tool in the case.

Any additional tools or accessories should be stored in the case.

Make sure the case is securely closed and latches are secure before lifting the carrying case.

SPECIAL TOOLS

All tools required for the safe operation and maintenance of this power tools are provided within the standard accessories, no additional tools should be required.

SETTING AND TESTING - USING THE SAFETY STRAP

A ratchet type safety strap is provided.

The power tool has 2 x 'D' loop rings to allow the hooks on the safety strap to be attached securely.

Always ensure the strap is correctly fitted and the machine is secure BEFORE starting the motor unit.

The safety strap is used to reduce the risk of injury in the case of a power supply or electrical malfunction.

The strap will hold the power tool if the electro-magnet loses its magnetic adhesion.

If the strap becomes damaged or lost, it must be replaced BEFORE using the power tool.

DO NOT use the safety strap as an alternative clamping method, the electro-magnet should have good magnetic adhesion at all times whilst using this power tool.

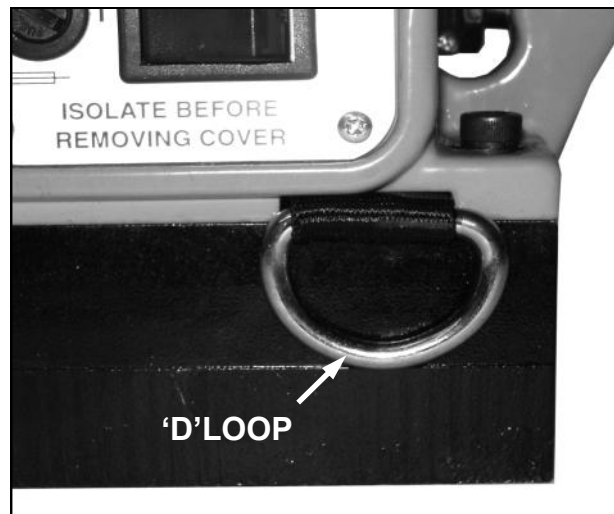
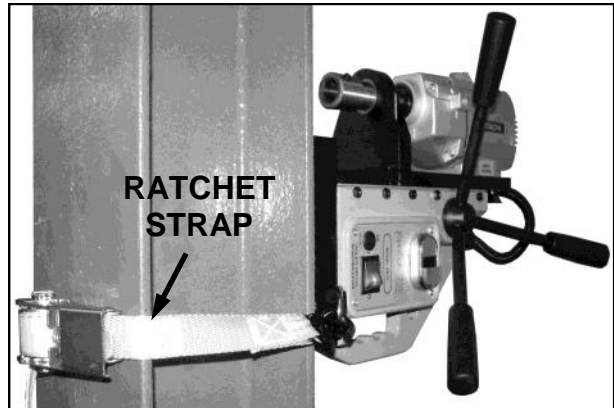

MOUNTING CUTTERS INTO THE ARBOR

The holder for the cutting tool is known as the arbor. The arbor is designed to accept Powerbor 3/4" Weldon shank annular cutters.

For cutters above 2 1/2" diameter a larger 1 1/4" arbor is required. (Part No.18Y105/A)

The Powerbor annular cutters normally have two flats disposed at 90° to each other.

To mount the cutter.

First ensure the ejector pin is in place.

Align the flats with the two fixing screws.

Push the cutter up into the arbor until it stops.

Tighten the two fixing screws onto the cutter flats with the hex keys supplied.

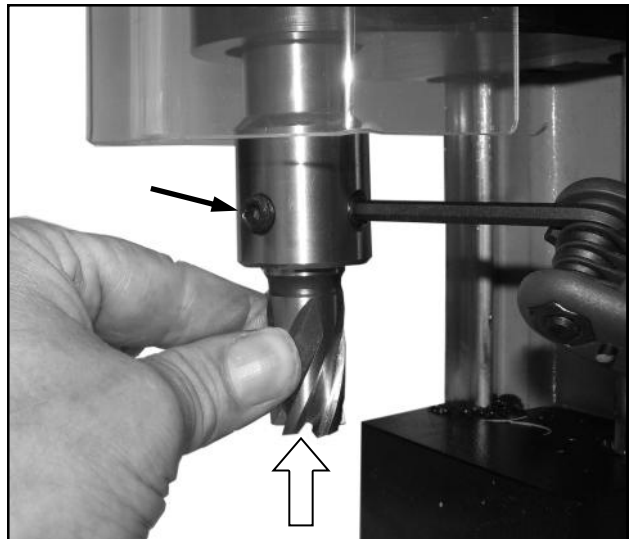

FITTING THE MT3 ARBOR

To fit the MT3 arbor (A) into the machine.

First ensure that both the arbor and the Morse taper socket are clean and free of dirt or debris and have no damage which could prevent the taper from seating correctly.

It may be necessary to turn on the magnet to hold the machine in position. Push the arbor into the spindle and then tap it home firmly, preferably with a copper mallet.

Check the security of the arbor before use.

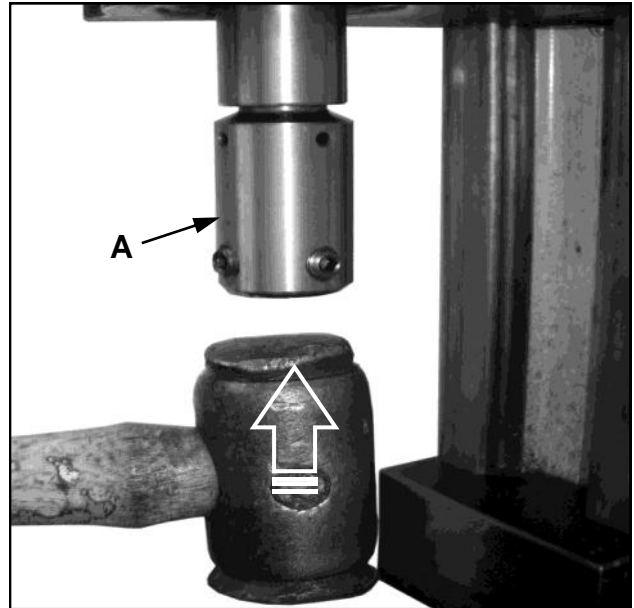

REMOVING THE MT3 ARBOR

Ensure the machine is turned OFF.

To remove the arbor (A), so that other tools or tool holders can be fitted into the MT3 socket, use the drill drift (B) supplied.

Locate the slot on the side of the gearbox, turn the spindle by hand so that the spindle slot is in alignment with the gearbox housing slot.

Slide the drill drift through the slot, as shown in the diagram opposite. Tap the drill drift where indicated on the diagram whilst supporting the arbor.

When the arbor is free of the taper it can be withdrawn from below.

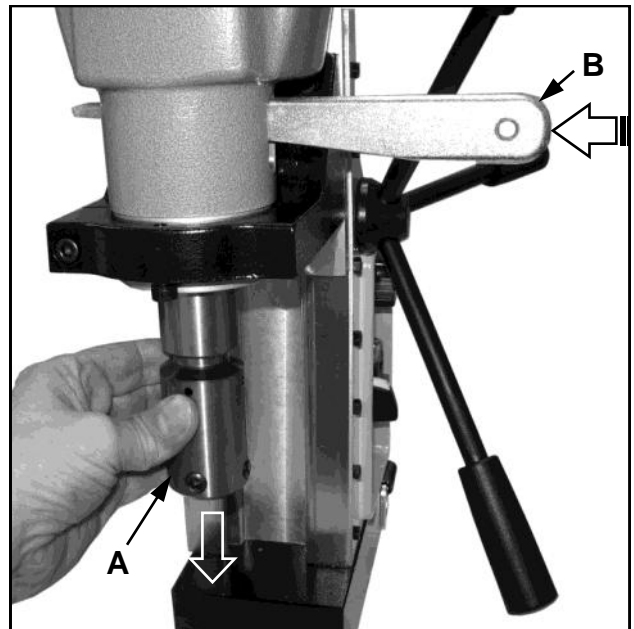

USING TWIST DRILLS

With the Weldon shank arbor removed, the electro-magnetic drill stand can be used with twist drills or any other suitable cutting tool or holder with a standard MT3 shank.

The PB1000E has a twist drill capacity of $\text{Ø}1\text{-}1/4\text{'}$.

For smaller twist drills a $5/8\text{'}$ 3 jaw chuck mounted on an MT3 shank can be used.

($5/8\text{'}$ MT3 Drill Chuck - Part No. 18Y109)



SAFETY GUARD

A safety guard is supplied with this power tool, it should be attached **BEFORE** using the power tool.

The guard is attached at 1 point, by a hexagon socket head fixing screw to the nose bracket. .

The adjusting screw should be tightened just enough to allow the spring washer to hold the guard up.

The guard has approximately 2" of travel which is adequate standard length cutters.

The guard should be adjusted so it is able to slide with light pressure.

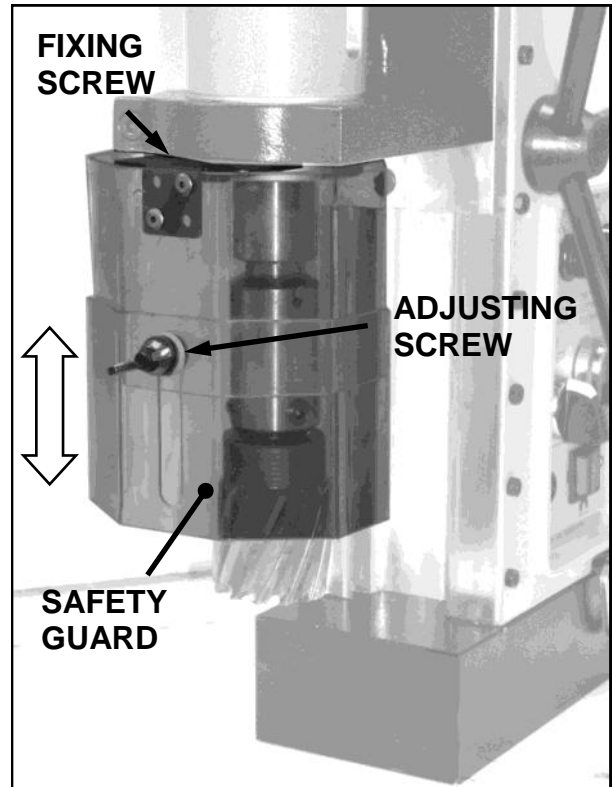

CLAMPING - MAGNET CONTROL

An electro-magnet is used for clamping the tool onto the workpiece.

The magnet is controlled by the magnet switch (F) located at the bottom of the control panel.

'O' indicates magnet OFF 'I' indicates magnet ON.

Ensure the magnet switch is OFF before connecting the power supply.

Ensure the magnet is clean and free from debris and that the machine is on a flat clean ferrous surface of the required minimum thickness (3/8").

To switch the magnet ON, press the switch to the 'I' position, the switch will illuminate to indicate there is a power supply to the machine.

The security of the magnet should always be physically checked **BEFORE** starting the drill unit.

The magnet is protected by a 20mm 2A fast acting fuse (G).

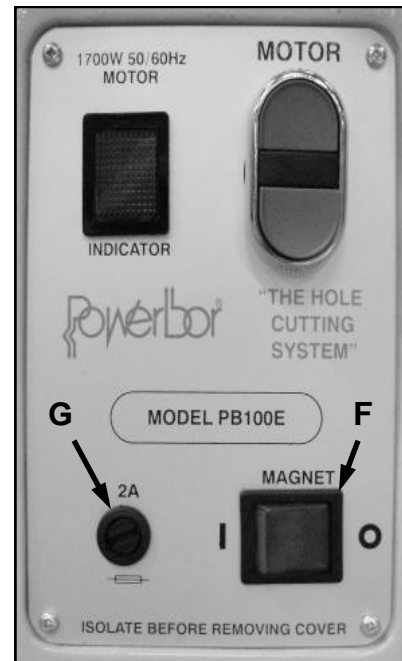

CUTTING SPEEDS/MATERIALS—HSS CUTTERS

The PB1000E is a 4 gear drill unit with nominal load speeds of 110/175/245/385 rpm. Under load the PB1000E will regulate its speed depending on the load applied. ie: a small cutter will run faster than a larger cutter (if the same feed rate is applied)

The PB1000E has the optimum power / torque / spindle speed for HSS annular cutters in the range Ø1/2" to Ø4", cutting EN10025 S235J steel or its equivalent.

The PB1000E can also be used on other materials such as high tensile steel and stainless steel if the appropriate speed for the material to be cut is selected.

Cutting Speeds—suggested speed rates for varying cutter diameters / materials

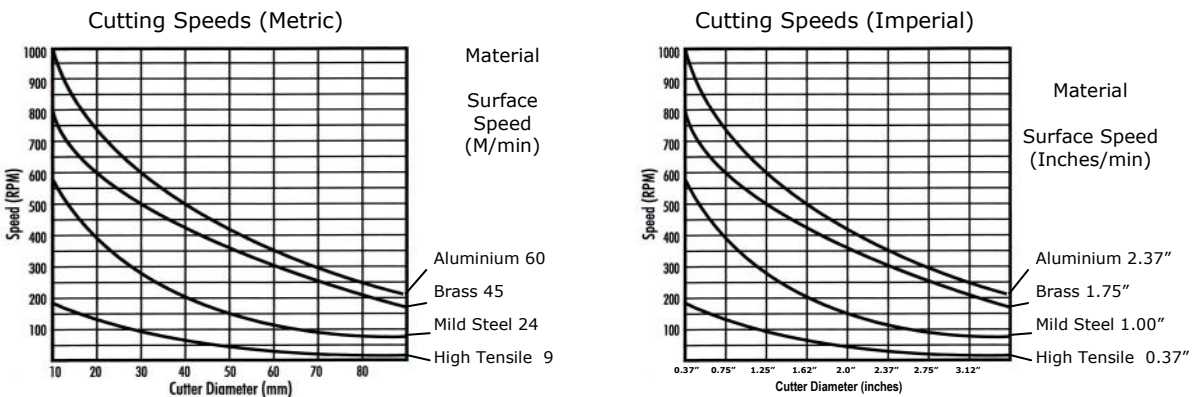

WORKPIECE MATERIAL AND SIZE LIMITATIONS - MAGNET

The electro - magnet clamping force is measured as the pull off load when clamped on a steel plate (EN10025 S235J or its equivalent) of 1" thickness, flat with a good surface and free from rust and debris.

For any other workpiece material the clamping force will be different, any difference in workpiece thickness and the clamping force will deviate.

The minimum recommended plate thickness for the electro-magnet is 1/2" thick.

If the workpiece is thinner than recommended then an additional plate, made of suitable material should be added by clamping to the workpiece, this will help the electro-magnet become more secure.

BEFORE using the drill always ensure the magnet is held onto the work piece securely.

OPERATION - SPINDLE - START / STOP

The drill unit or “motor” is controlled by a twin push button switch (H) at the top of the control panel.

The green button is ON the red button is OFF.

The green button is flush with the surrounding bezel.
The red button is raised above the surrounding bezel.
This is to prevent inadvertent operation of the drill unit.

The motor will not operate unless the magnet is switched ON first.

BEFORE starting the motor, the security of the magnet should be physically checked, if any movement is possible this should be rectified BEFORE using the drill.

The motor control has an under-voltage relay, if the power is interrupted the motor will stop and will not restart when the power is resumed until the motor control is operated again.

The motor indicator neon (L) illuminates to show when the motor has a power supply.



OPERATION - SPINDLE SPEED - CONTROL

The speed of the motor on the PB1000E can be controlled by changing the gear ratio switches (J or K) to position I or II. The gear selector switches are located on either side of the drill unit gearbox when viewed from the front.

Gear Selection

To change the gear ratio, consult the chart on the right or the speed label on the machine, locate the gear selector on the side of the motor gearbox. Press the selector in against the spring, slide up or down to choose the appropriate speed.

The selectors have two positions I = Down and II = Up
The selectors may have one or two triangular symbols as shown in the diagram to the right.

As viewed from the front		
SPEED	LEFT	RIGHT
110	Down	Up
175	Down	Down
245	Up	Up
385	Up	Down

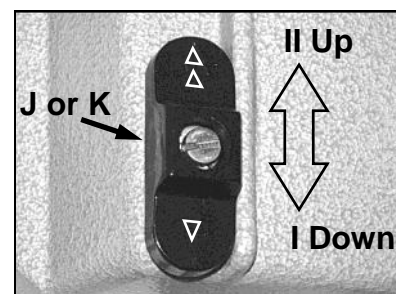

OPERATION - REVERSING OF THE HANDLES

The three handles (C) which raise and lower the drill unit are attached to the pinion shaft (D).

These handles and the pinion shaft itself can be turned around so the handles can be used on each side of the machine. This is useful if access is limited on one side of the machine because of the machines location.

The handles are normally mounted on the same side as the controls, if they need to be reversed the following procedure should be used.

First, the drill unit and its slide should either be supported or put into its lowest position to prevent the risk of it falling when the pinion is disengaged.

The hexagon head cap screw in the end of the pinion shaft end cap (E) should be unscrewed.

The pinion shaft end cap can then be removed, the pinion shaft and handle assembly can be withdrawn.

The pinion shaft and handle assembly can then be mounted on the opposite side of the machine, taking care to ensure the pinion gear teeth engage with the rack teeth.

The pinion shaft end cap and its hexagon head cap screw

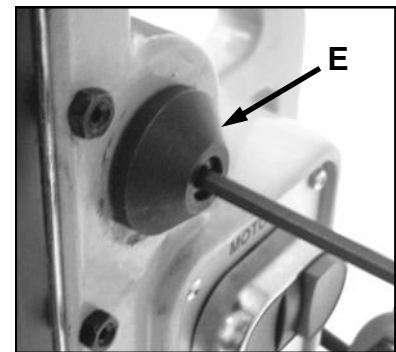
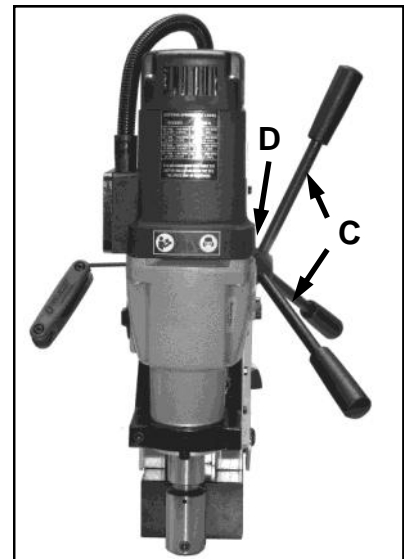

OPERATION - NORMAL OPERATOR POSITION

The normal operator position is as shown in the image on the right, in general it is best to use the machine from in front of the control panel so that all the operator controls are visible and easily accessed.

There are occasions with this type of machine that it is used horizontally or even upside down. Extra care should be taken in these circumstances and access to the machine controls should be maintained.

The pinion shaft can be reversed on this type of machine to allow the drill better access in confined spaces. When the handles are reversed, again the operator should still have full access to the control panel before using the machine.



OPERATION - USING THE DRILL WITH ANNULAR CUTTERS

Insert the correct pilot pin into the pilot pin hole through the shank of the cutter.

Mount the cutter in the tool holder (arbor) of the machine as described in previous chapters, ensuring the cutter is secure and correctly fitted.

Position the machine on the work piece ensuring the magnet is on a flat clean ferrous surface and the work piece is not below the minimum recommended thickness.

Use the pilot pin to align the centre of the cutter to the desired hole position.

Switch on the magnet and physically check the machine is securely adhered to the work piece.

Once in position, attach the safety strap, if the magnetic adhesion fails for some reason the safety strap will reduce movement of the machine.

Apply cutting fluid through the small holes in the arbor, the arbor has a small reservoir for coolant which is fed down through the central pin hole to the cutter. The use of cutting fluid will enhance the quality of the cut and prolong the life of the cutter.

Lower the safety guard provided.

Switch on the drill motor, feed the cutter down by using the three handles provided. Proceed with caution, apply pressure gradually until the cutter has formed a groove of approx 1/8". Once a groove is established the pressure can be increased.

DO NOT apply excessive pressure, if excessive pressure is required it is a sign the cutter may be worn, continuing to use a worn cutter will result in damage to the drill motor.

If the drill motor slows significantly under load ease off the downward pressure.

On deep holes it may be necessary to withdraw the cutter to remove swarf and to apply more cutting fluid.

A cutter in good condition will need only moderate feed pressure and will produce continuous chips or swarf. Broken chips or swarf indicate a cutter or material problem, so care should be taken.

OPERATION - BLOCKAGES OF CHIPS AND WORKPIECE FRAGMENTS

If excessive swarf builds up during the cut it may be necessary to withdraw the cutter to remove the swarf, care should be taken as the swarf will be both hot and sharp.

As the cutter begins to break through, the feed pressure should be reduced slightly.

When the cutter breaks through, a slug of material at the centre of the cut will be ejected. This will be both hot and sharp. Care should be taken when handling the slug.

Care should be taken that the ejection slug is safe and can not injure anyone in the vicinity, the slug should be prevented from falling where possible.

MAINTENANCE - GENERAL

To keep this machine in a safe working condition regular certain maintenance is required.

1. The gib strip on the dovetail slide must be adjusted to eliminate any free play.
2. The dovetail slides will need to be lubricated with oil periodically.
3. The magnetic base should be inspected for damage on its magnetic surface or for any damage to the resin, any damage should be repaired before using the drill.
4. A monthly inspection of the carbon brushes is recommended, excessive wear could lead to motor damage or malfunction.

MAINTENANCE - REPLACING BRUSHES

The carbon brushes are located under the motor end cap, to remove this, unscrew the 4 fixing screws and withdraw the end cap.

The carbon brushes (N) can then be removed by unscrewing the screw (O) and pulling out the spring (P).

The brush can then be removed, simply withdraw the brush to inspect or replace it.

When replacing the brush, slide it into the brush

wires with the fixing screw (O), then replace the motor end cap. The brushes on this drill unit have an auto stop feature, when the brush reaches its wear limit the motor will stop until the brushes are replaced. For best performance and reliability always use genuine replacement

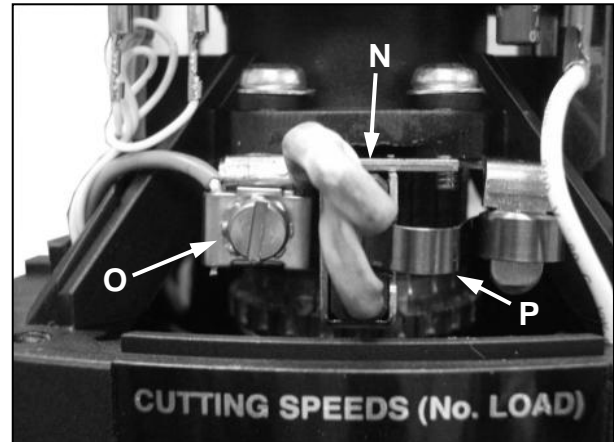

ACCESSORIES



18Y170
CHUCK ADAPTOR

This allows a drill chuck to be quickly placed into the arbor of the machine.

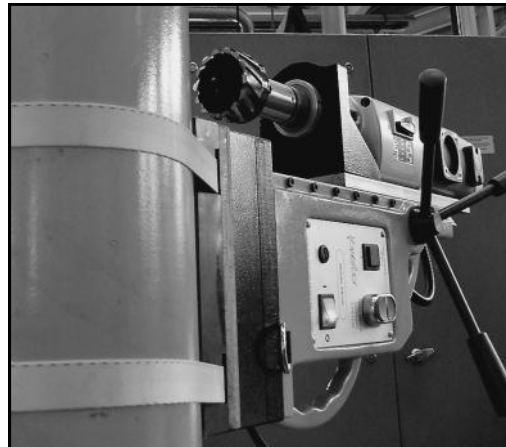

18YPIPE PIPE CLAMP

This allows the drill to be mounted on a pipe or cylindrical object, the magnet attaches to the "saddle" so the material of the workpiece does not need to be magnetic.



18Y109
MT3-5/8" DRILL CHUCK

This allows the machine to use any tool with a parallel shank up to 5/8" diameter.

MAINTENANCE - TOOL USE AND CARE

Always ensure the work piece is secure and stable before attempting to work on it.

Do not force the tool, always use the correct type of cutting tool for your application and use it at the rate it was designed to work at.

Do not use the power tool if the power switch does not turn it on or off, any tool which can not be turned on or off with the switch is dangerous and must be repaired before use.

Always disconnect the plug from the power supply before making any adjustments, changing accessories or storing the tool. This will prevent the risk of the starting the tool accidentally.

Always store tools not in use out of reach of children and untrained persons. Tools are dangerous in the hands of an untrained user.

Maintain all cutting tools with care, keep them sharp and clean, properly maintained tools with sharp edges are less likely to bind and will be easier to control.

Do not operate the power tool with dull or damaged cutting tools, this may overload the motor.

Check the power tools periodically for misalignment or binding of moving parts, also broken parts or any other condition that may affect the tools operation. If damaged have the tool serviced before using, Poorly maintained tools can cause accidents.

Use only Powerbor recommended accessories, accessories made for other power tools may not be suitable and could become hazardous when used.

SERVICE

Only trained repair personnel should perform tool service. Service or maintenance performed by untrained personnel could result in a risk of injury.

When servicing the power tool, only use identical replacement parts, pay attention to the power tools voltage rating and model number to ensure the correct replacement parts are specified.

WARRANTY

POWERBOR WARRANTY STATEMENT

Powerbor warrants its magnetic drills for one (1) year from the date of purchase against defects due to faulty material or workmanship and will repair or replace (at its option) without charge, any items returned. This warranty is void if the item has been damaged by accident or unreasonable use, neglect, improper service or other causes not arising out of defects in material workmanship. No other expressed warranty is given or authorised. Powerbor disclaims any implied warranty of merchantability or fitness for any period beyond the expressed warranty, and shall not be liable for incidental or consequential damages. To obtain warranty service, return the item(s) to your nearest factory authorised repair centre.

This warranty is on lieu of any other warranty, expressed or implied, including any warranty of merchantability or fitness for a particular purpose.

POWERBOR PB1000E

STAND PARTS

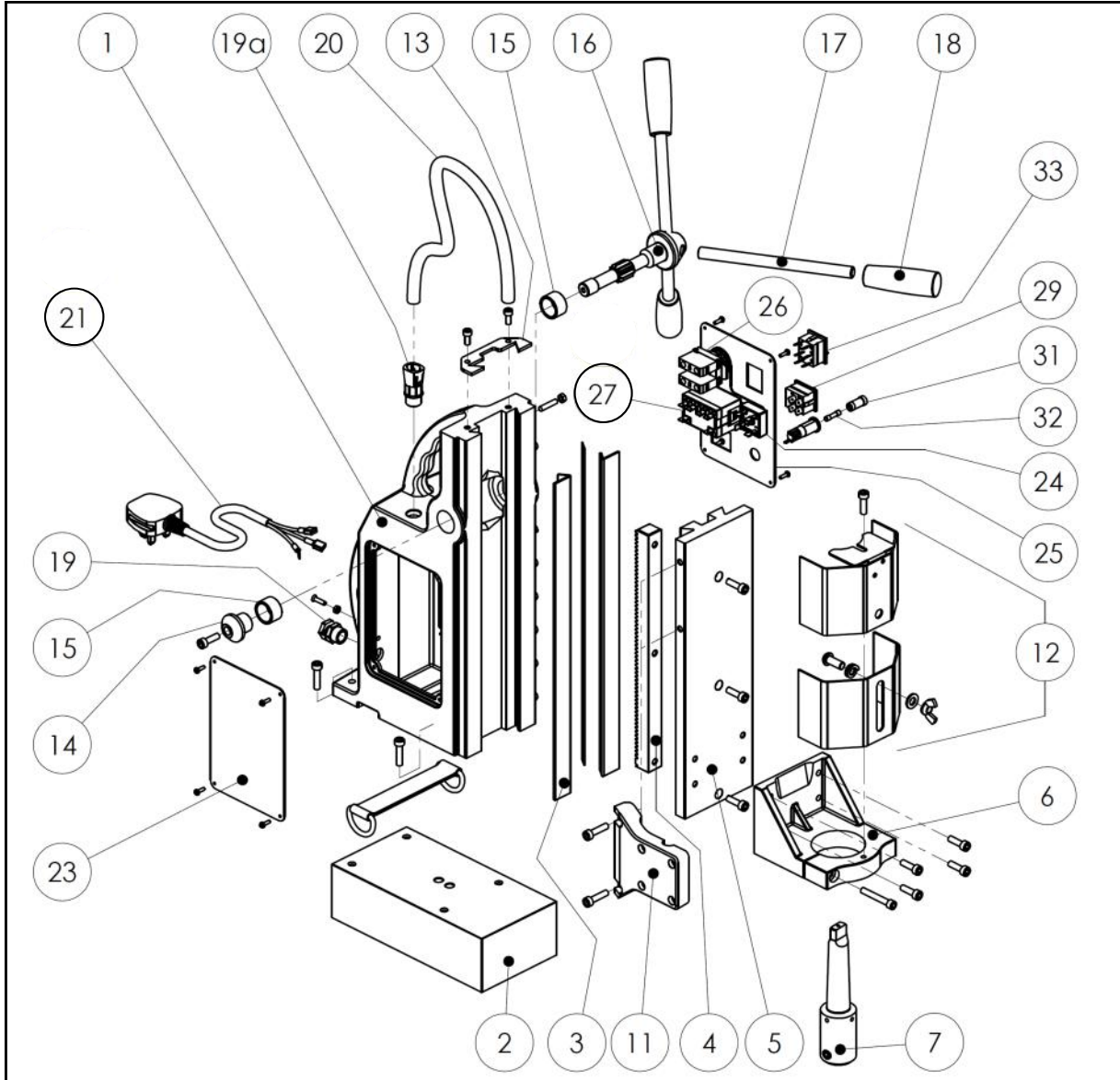

Item	Part No.	Description
1	18Y150	MAIN BODY CASTING PB1000
2	18Y135	MAGNET BASE
3	18X613	BRASS GUIDES (PAIR)
4	18Y142	MACHINE RACK
5	18X604	DOVETAIL SLIDE (330mm)
6	18X6051	LOWER SUPPORT CASTING
7	18Y102	MT3 ARBOR COMPLETE
8	18X6271	MT3 ARBOR SPRING
9	18X628	MT3 ARBOR PISTON
10	18X206	19MM INTERNAL PISTON
11	18X6231	SIDE FIXING CASTING
12	18Y153	DRILL GUARD
13	18X612	RETAINING BRACKET
14	18X524	PINION END CAP BUSH
15	18X502	PINION BUSH
16	18Y154	PINION SHAFT

Item	Part No.	Description
17	18X718	HANDLE
18	18X520	KNOB
17+18	18Y156	HANDLE & KNOB
19	18X430	CABLE RESTRAINT
19A	18X519/A	CONDUIT GLAND
20	18Y184	CONDUIT LEAD
21	18X503/A	MAINS CABLE 110V US
23	18X1025	REAR PANEL PLATE
24	18X515	BRIDGE RECTIFIER
25	18X1020	CONTROL PANEL PLATE
26	18Y182	START/STOP SWITCH ASSY
27	18X513	RELAY - 110V
29	18X510	MAGNET SWITCH
31	18X511	FUSE HOLDER
32	18X512	2A FUSE
33	18X624	NEON INDICATOR LIGHT

POWERBOR PB1000E

DRILL UNIT PARTS

Complete Drill Unit 110V 18X6081

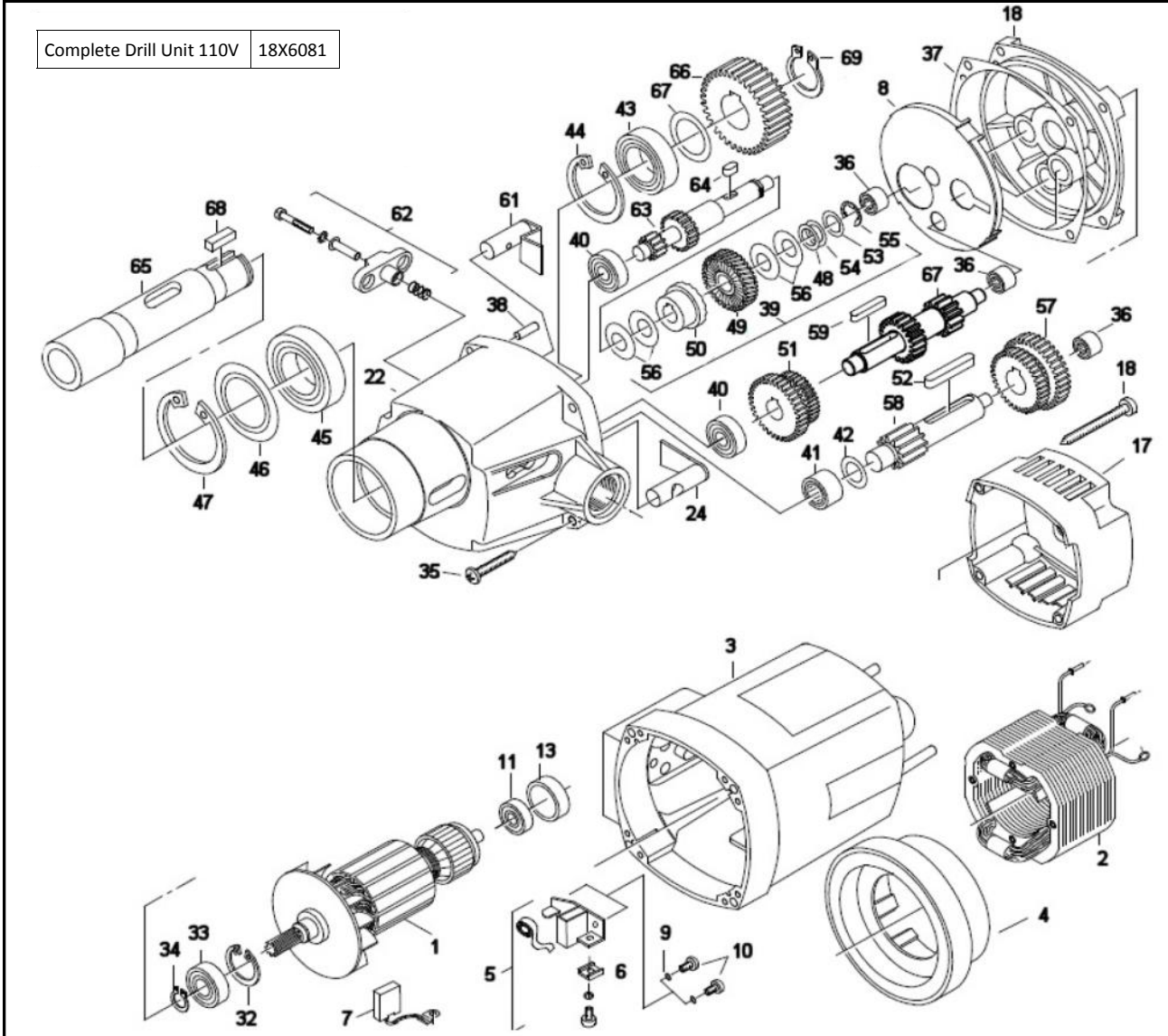

Item	Part No.	Description
1	18ZG01	Armature 110V
1a	18ZG01/A	Armature 230V
2	18ZG02	Armature 110V
2a	18ZG02/A	Armature 230V
3	18ZD03	Motor Housing
4	18ZD04	Air conductive ring
5	18ZD05	Brush Holder Complete
6	18ZD06	Contact Washer
7	18ZD07	Carbon Brush Set
8	18ZE08	Grease barrier EIB 80900110
9	18ZD09	Spring Washer
10	18ZD10	M4 Screw
11	18ZD11	Grooved Bearing
13	18ZD13	Bearing Cap
17	18ZD17	Motor Housing Cap
18	18ZD18	Self Tapping Screw 4.8x45
22	18ZE22	Gearbox Housing EIB 7154A400
24	18ZE24	Gear Selector 2 EIB 71540530

Item	Part No.	Description
32	18ZD32	Circlip 28/1.2
33	18ZD33	Grooved Bearing 6001 2Z
34	18ZD34	Circlip 11/1
35	18ZD35	Self Tapping Screw HC 5.5x38
36	18ZD36	Needle Sleeve HK0810
37	18ZD37	Gearbox Seal
38	18ZD38	Pin
39	18ZE38	Clutch assembly EIB 7154A493
40	18ZD40	Grooved Bearing 6000
41	18ZD41	Needle Bearing RNA 4900
42	18ZD42	Washer
43	18ZD43	Grooved Bearing 6005 2RS
44	18ZD44	Circlip 47/1.75
45	18ZD45	Grooved Bearing 6006 2RS
46	18ZD46	Washer
47	18ZD47	Circlip 55/2
48	18ZE48	Thrust washer EIB 80200503
49	18ZG49	Coupling Wheel

Item	Part No.	Description
50	18ZD50	Gear Coupling Half
51	18ZE51	Gear Cluster 1 EIB 71540440
52	18ZE52	Key 6x6x40 EIB 80200608
53	18ZE53	Lock Washer EIB 85000004
54	18ZD54	Thrust Washer EIB 85000003
55	18ZD55	Circlip 9
56	18ZD56	Disc Spring 28/12.2x1
57	18ZE57	Gear Cluster 2 EIB 71540450
58	18ZE58	Int. shaft 3 EIB 71540510
59	18ZE59	Key 6x6x40 EIB 80200602
61	18ZE61	Gear Selector 1 EIB 71540520
62	18ZD62	Gear Selector Complete
63	18ZE63	Int. shaft 1 EIB 71540490
64	18ZE64	Key 5x5x10 EIB 71540495
65	18ZD65	Spindle
66	18ZD66	Spindle Gear
67	18ZE67	Int. Shaft 2 EIB 71540500
68	18ZD68	Key 6x6x20
69	18ZD69	Circlip 24/1.2

MT3 ARBOR

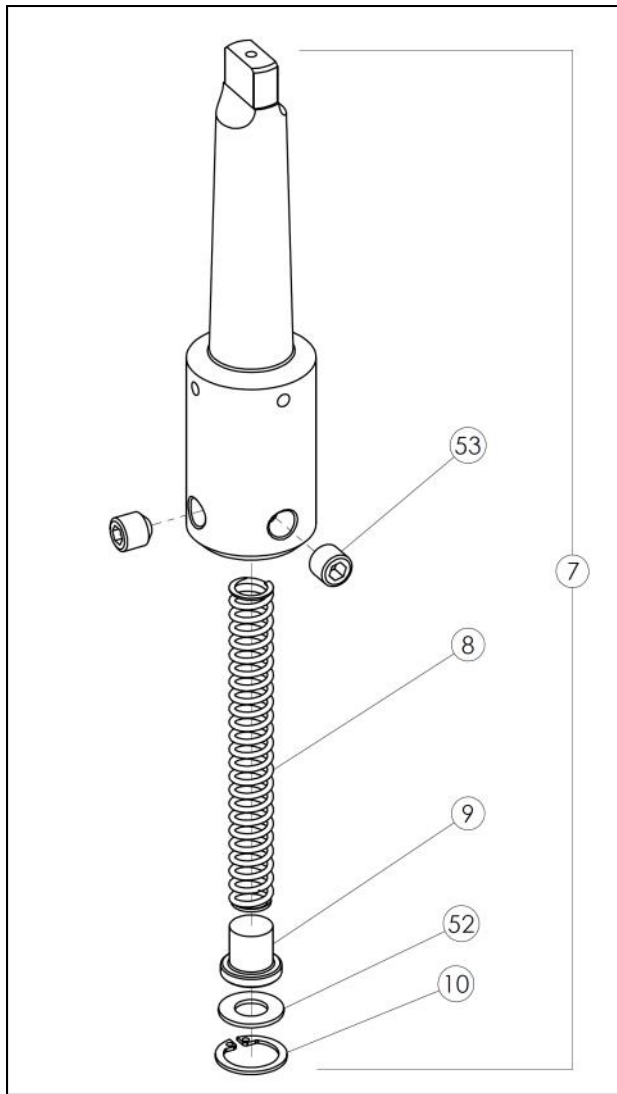

Item	Part No.	Description
7	18Y102	MT3 ARBOR COMPLETE
8	18X6271	MT3 ARBOR SPRING
9	18X628	MT3 ARBOR PISTON
10	18X206	19MM INTERNAL CIRCLIP
52	18X207	MT3 ARBOR WASHER
53	18X204	M10 x 10 CUP POINT SCREW

PB1000E DRILL GUARD

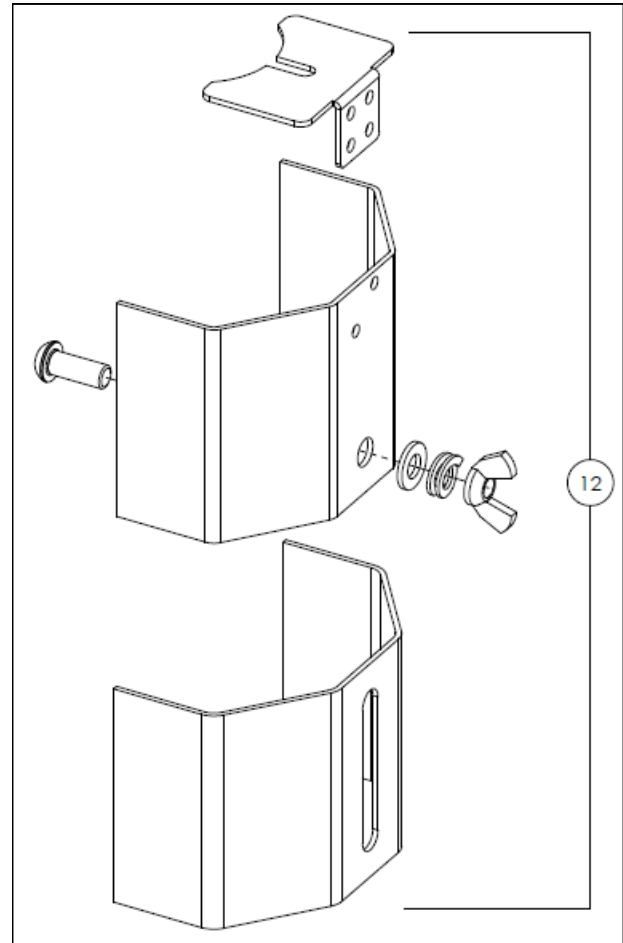

Item	Part No.	Description
12	18Y153	DRILL GUARD

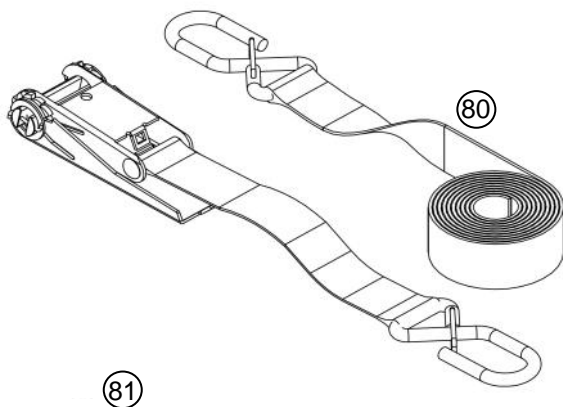

PB1000E SAFETY STRAPS

Item	Part No.	Description
80	18X535	HOOK STRAP ASSEMBLY
81	18X533	RATCHET STRAP ASSEMBLY

PB1000E SB — OPTIONAL SWIVEL BASE PARTS

ITEM	PART No	DESCRIPTION
1	18Y135S	MAGNET
2	18X344	BASE PLATE
3	18X342	SPACER PLATE
4	18X343	CLAMP PLATE
5	18X341	STUD
6	18X340	LARGE WASHER
7	18X336	M20 NYLOC NUT DIN 985 TYPE "T"
8	18X339	CAM
9	18X335	GLACIER BUSH FMB 1612 DU
10	18X337	HANDLE 3282/M
11	18X338	WASHER 19.7 x 6.5 x 1.6
12	18X201	M6 x 20 SHCS
13	18X249	M5 x 10 SHCS

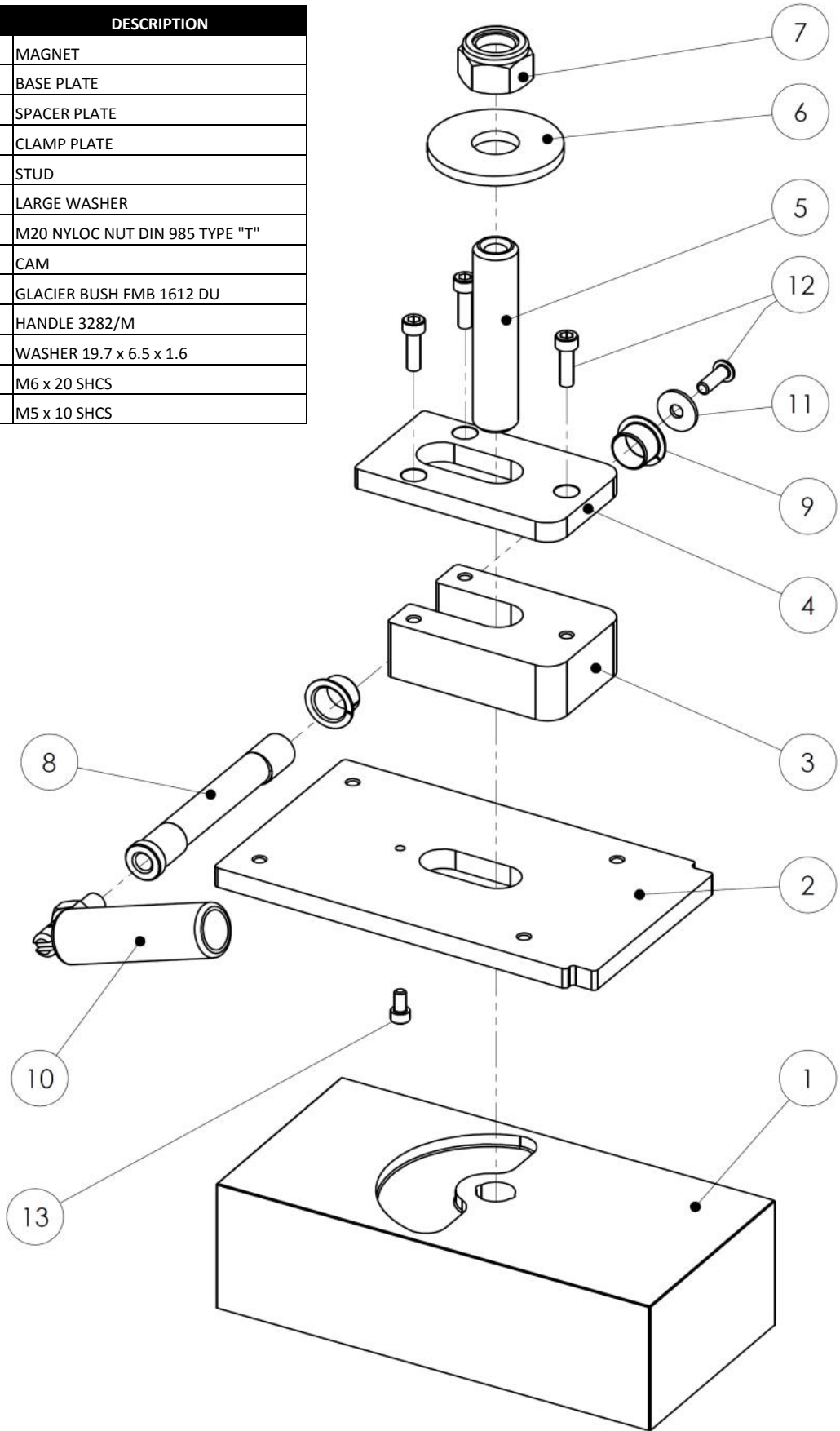

CE Declaration of Conformity

On our sole responsibility we declare that this product, the Powerbor PB1000E Drill, is in conformity with the following standards and standard documents :-

- EN61029-1:2009 - Safety of Transportable Motor Operated Electric Tools
- EN61000-6-2:2005 - Electromagnetic Compatibility (EMC). Generic standards. Immunity standard for industrial environments
- EN61000-6-4:2007 - Electromagnetic compatibility (EMC). Generic standards. Emission standard for industrial environments

According to the regulations :-

- 2006/95/EC - Low Voltage Directive
- 2004/108/EC - EMC Directive
- 2006/42/EC - Machinery Directive

Signed..........
(P.D. Edwards - Managing Director)

Date....19.04.11

G&J Hall Inc
830 Hanley Industrial Court
Brentwood
MO 63144
United States of America

Phone: (314) 968-5040
Fax: (314) 968-5543
Email: sales@gjhalltools.com
Web: www.gjhalltools.com

WARRANTY REGISTRATION

Thank you for purchasing your Powerbor® magnetic based drilling machine. To ensure any warranty claim can be processed promptly, please register your machine, now, on-line at :-

<http://www.gjhall.co.uk>

Click on the button on the left "POWERBOR WARRANTY REG"